



Systems for
swing gates



SEA[®]
electronic opening system

Mini Tank

Hydraulic swing gate operator for
residential use
(leaf: length max 3 m)



- Hydraulic operator for swing gates satisfying the requirements of very exigent customers regarding quality and long time lasting.
- Hydraulic silence and reliability.
- SEA TOTAL QUALITY: All main parts are manufactured and tested in-house.
- The functioning of the operator through oil and the inner lubrication of all mechanical components grant a long time lasting.
- Extremely silent.
- Available in the versions with lock in closing (SC) and without lock (SB) with max 270mm run.

Mini Tank

TECHNICALS PECIFICATIONS

Specifications	Mini Tank
Power supply	230 Vac±5% 50/60 Hz
Motor power	180 W
Shaft Stroke	270 mm
Cycles/hour	40
Oper. temperature	from -20 °C to + 55 °C
Weight	10 Kg
Max leaf length	3 m
Opening degrees	90 ° - 120 °
Shaft speed	1,5 cm/s (pump 1l)
Protection class	IP 55
Starting capacitor	12,5 µF
Max thrust	250 daN

Release with key in case of electric power failure.



Anti-crushing security through force adjustment by-pass valves



Swing 2

- Management of two 230 Vac motors without limit switch
- Automatic, semiautomatic, semiautomatic of security
- Adjustable slow down in opening and closing
- Motor couple adjustment
- Self-learning working times
- Auto-test on photocell
- Auto-diagnostic
- Electric lock management
- Encoder administration (also Safety GATE for swing gates)
- Diagnostic Leds on all outputs/inputs
- Extractable connectors
- Integrated radio decoding compatible with radio transmitters SMART, HEAD ROLL, COCCINELLA and SMART ECOPIY (800 users) series with optional RF radio frequency module (RF)
- Encoder sensibility adjustment (Safety GATE)
- Pedestrian opening
- Max. transformer output capacity 200mA
- Photocells administration in opening and closing
- Stop administration
- Pre-flashing
- Inversion stroke
- Programming trough PALM.

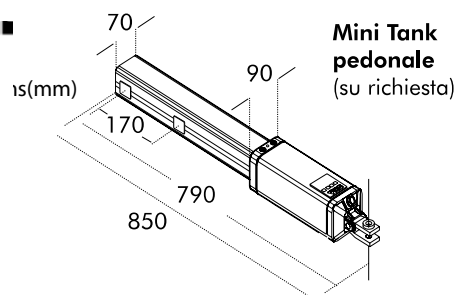
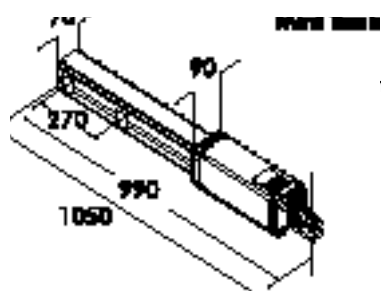

Mini Tank pedonale (su richiesta)

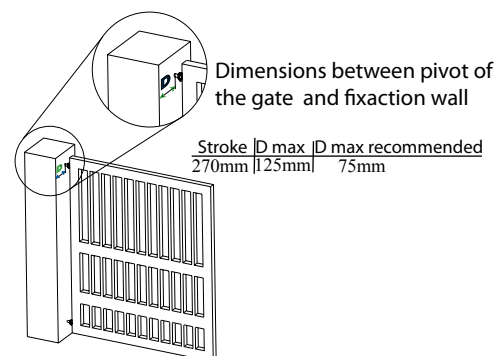

Standard installation

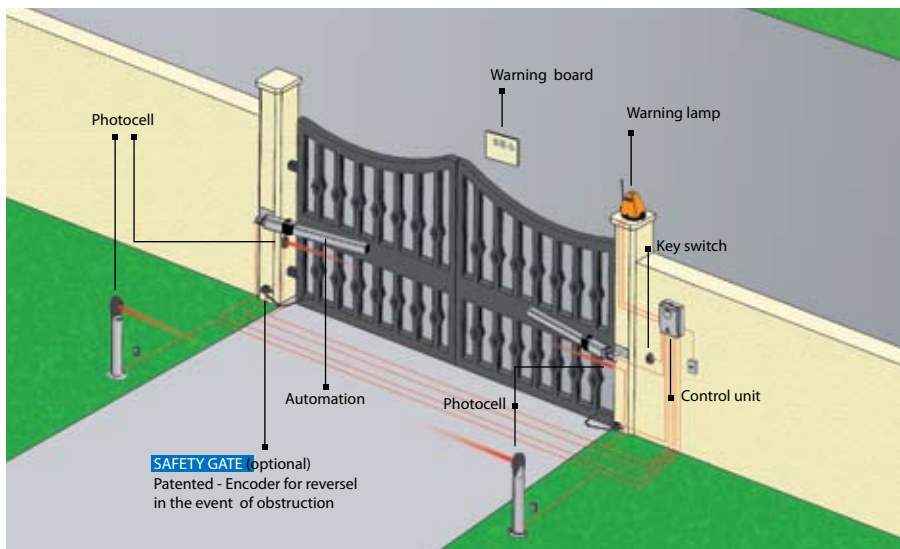

AC	SB	SC	SA
double lock	without lock	lock only in closure	lock only in opening



lock available
NOTE: In case of installations in very windy places or with closed panelled gates SEA recommends to choose operators without lock (SB).



Zona Industriale S. Atto (TERAMO) ITALIA
Tel. +39 0861 588341 r.a. Fax +39 0861 588344
seacom@seateam.com - www.seateam.com

